



Under the Patronage of His Royal Highness Prince
Khalifa bin Salman Al Khalifa
The Prime Minister of the Kingdom of Bahrain



45TH IFTDO

WORLD CONFERENCE & EXHIBITION

LESSONS FROM LEADERS

21st-23rd March 2016

Bahrain Conference Center - Crowne Plaza, Kingdom of Bahrain





His Royal Highness Prince
Khalifa bin Salman Al Khalifa
Prime Minister



His Majesty King
Hamad bin Isa Al Khalifa
King of the Kingdom of Bahrain



His Royal Highness Prince
Salman bin Hamad Al Khalifa
Crown Prince & Deputy
Supreme Commander
First Deputy Prime Minister



45TH IFTDO

WORLD CONFERENCE & EXHIBITION



THE DESTINATION

The Kingdom of Bahrain is an archipelago made up of 33 islands located in the Arabian Gulf between the Kingdom of Saudi Arabia and State of Qatar and its total area is 780 km².

The earliest human settlement in Bahrain's islands dates back to almost 4,000 years ago. Over that time, it was inhabited by a series of different civilizations, starting with Dilmun, then Tylos, and finally the Islamic period.

Manama is the capital of Bahrain and it is the largest city. Manama enjoys a distinct reputation as a tourism and cultural hub regionally and internationally, branded by selecting Manama as the Capital of Arab Culture in 2012, the Capital of Arab Tourism in 2013 and the Capital of Asian Tourism in 2014.

Bahrain is a country that prides itself as being a thriving multi-cultural pivot, which welcomes people from all around the world, thanks to its tolerant attitudes, low cost of living, and abundance of educational and health facilities and services. According to the latest e-Government portal statistics, Bahrain's population is currently around 1.2 million Bahrainis and residents.

Bahrain is considered as an important regional economic and financial center, and it is a base to a large number of global financial services companies. The kingdom is also laid out a comprehensive and integrated economic vision which aims to make its economy sustainable by the year 2030.



BAHRAIN MESSAGE



Bahrain Message

Dr. Ebrahim Al Dossary

Dear Colleagues and Friends,

As a Board Member of IFTDO and the Honorary President of BSTD, I am extremely pleased and honored to welcome you to the 45th IFTDO World Conference and Exhibition in Bahrain in 2016 under the engaging theme 'Lessons from Leaders'.

It is a privilege and honor to have you in the Kingdom of Bahrain, a country that has always been a living example of peaceful coexistence between different cultures and diverse nationalities. Over the years, Bahrain has consistently led all efforts to support the exchange of knowledge and information, and strengthen the relationship and cooperation amongst all communities residing here. Bahrain has continued its onward march towards overall development guided by the principles of Bahrain Royal Family.

We, in Bahrain, take great pride in and cherish our achievements in the field of human development which remain at the top of our main priorities since the start of education in 1919 in Bahrain. We believe that human development is the most valuable asset for nations and people across the globe. Therefore, we have established institutes and developed very high quality frontline development programs to prepare and groom our younger generations to be our future leaders, as we firmly believe that wise leadership is the basis of all progress and is also the instrument of laying the foundations for the renaissance of any country.

In this conference, we will introduce a completely new concept that will focus on the latest studies, insights, and scientific research that pertains to the topic under discussion and address the impact of the human capital development on the progress and advancement of nations and their aspiration for prosperity and advancement.

Participants will be involved in brainstorming activities, workshops, open discussions and practical applications under the supervision of the best leaders, experts, scholars, researchers and intellectuals at the local, regional and global level. Those activities will be useful to formulate our vision and extend the scope of our reach through the practical and scientific suggestions and recommendations

We warmly welcome you all, to attend and wholeheartedly participate in this important conference. We wish you a pleasant stay in the Kingdom of Bahrain and hope you will enjoy our hospitality. We are committed to make your stay comfortable and thought provoking.

Dr. Ebrahim Al Dossary
BSTD Honorary President
IFTDO – Board Member

PRESIDENT MESSAGE

President Message

Mr. Mohamed Mahmood



Dear Conference Participants,

We as Bahrain Society for Training and Development (BSTD) and the event manager Origin Group take the pleasure to welcome you to the 45th IFTDO World Conference & Exhibition which will be held from 21st - 23rd March 2016, at the Bahrain Conference Centre, Crowne Plaza Hotel, Kingdom of Bahrain under the patronage of His Royal Highness Prince Shaikh Khalifa bin Salman Al Khalifa - The Prime Minister of the Kingdom of Bahrain.

The objective of this Conference & Exhibition is to explore live case leadership strategies from leaders around the world, pass lessons and Leadership through their success stories with particular emphasis on the positive impact achieved in the human capital and in the business.

For this, we are pleased to have in this conference a very high profile distinguished speakers from Bahrain, GCC and international, who are very inspirational and motivators for uplifting the excellence of Leadership qualities at our Organizations from their lessons in leadership and best practices.

The event will also include an Exhibition that will act as a network to showcase products, services, exchange ideas and experiences of the participants and their respective organizations.

The 45th IFTDO Conference & Exhibition is an opportunity to refocus our attention and energy on this most vital Human Capital and Competency issue for Bahrain, the wider Middle East and the world. It is also an ideal opportunity to share best practices and meet key personnel within Bahrain and the MENA Region.

Eng. Mohamed Mahmood Al Shaikh
BSTD President
IFTDO45 President

ABOUT IFTDO

ABOUT IFTDO



The International Federation For Training and Development Organization (**IFTDO**) is a worldwide network of human resource professionals committed to identifying, development and transferring knowledge, skills and technology to enhance personal and organizational growth, human performance, productivity, and sustainable development. Accredited as a Non-Government Organization by the UN Department of Public Information and the ILO, it helps to ensure that members' voices are heard by international policy makers influencing outcomes in human development. A diversified network of human

resource management and development organizations, IFTDO links HR professionals in HR societies, corporations, universities, consultancies, government organizations and enterprises .

Through its member organizations it represents more than 500,000 professionals in over 50 countries. IFTDO was founded in Geneva, Switzerland in 1972 in order to develop and maintain a worldwide network committed to identify, develop and transfer knowledge, skills and technology to enhance personal growth, human performance, productivity and sustainable development.

ABOUT BSTD



The Bahrain Society for Training & Development (**BSTD**) is a professional society for people involved in human resource management and development in Bahrain. BSTD, a non-profit making organization, as first established in 1979 and relaunched in April 1994 with renewed enthusiasm as a proactive society. Since then, it has gone from strength-to-strength greatly expanding its activities, interests, and membership, as well as linking internationally with HR professional bodies including IFTDO and ARTDO of the UK. Today, BSTD is fully revitalized and playing a significant role in enhancing HRD in Bahrain Originally launched in 1979, BSTD



is now actively involved in every aspect of human resource development, and supports and contributes to the promotion of human resource management at both national and international levels.

ABOUT THE CONFERENCE



Why this Conference?

The 45th IFTDO Conference & Exhibition offer up-to-date, relevant and engaging learning activities and serious success stories on learning and development and how leaders manage talents. Therefore, it is a unique opportunity for any delegate to maximize his/her knowledge of how to better manage people and resources. Our learning events provide practical tips through case studies, proven effective methodologies and fresh ideas from local, regional and international practitioners, CEO's, professionals, consultants and academics.

Who should attend

- CEO's
- Training Advisors
- Trainers
- Learning Specialists
- HRD Directors
- Training Managers
- Teaching Professionals
- Line Managers
- L & D Professionals
- Heads of Training and Development
- HR Managers
- Supervisors

Language

The conference language is English.

Fees

Non IFTDO Members	: \$ 1350 / BHD. 510
IFTDO Members	: \$ 1250 / BHD. 475
Accompanying Person	: \$ 550 / BHD. 208
Pre-conference workshop only	: \$ 160 / BHD. 60

The conference fee will include:

- Attending one of the pre-conference workshops.
- All conference sessions.
- The gala dinner.
- The exhibition.
- Full conference materials.
- Lunch, tea and coffee.
- A certificate.

LESSONS FROM LEADERS

Focusing on Learning and Development Practices

The most successful and enduring businesses are those that combine a meaningful purpose and a clear set of values and have leaders who display both rational and emotional intelligence of a high order. This conference will focus on many success stories from hands on leaders with great lessons which has enabled them at all levels to reflect on these challenges in a highly engaging and compelling way.

According to Prof. Dave Ulrich and many management gurus that failure of many organizations are because of lacking professional leaders and management strategies. Behind every successful organization stands a great leader as the likes of Microsoft with Bill Gates, Apple with Steve Jobs and General Electric with Jack Welch.

OFFICIAL OPENING OF CONFERENCE

CULTURE HALL, BAHRAIN NATIONAL MUSEUM



Opening Ceremony

19.00 – 22.00



Recitation from the Holy Quran



MC Opening speech



President Message

Eng. Mohamed Mahmood Al Shaikh

BSTD President / IFTDO45 President



Introducing IFTDO Board Members



Keynote Speaker

The future is today

Leadership & Change Management

H.E. Dr. Abdul Hussain bin Ali Mirza

Minister of Energy - Kingdom of Bahrain



Awards recognition



Group photo



Dinner

PROGRAMME AT A GLANCE

Day One

Monday, 21st March 2016

Registration & Networking

08.00 – 15.00

Registration desk will be opened until 15:00 hrs
Other activities will follow until 14:00 hrs.

Exhibition install

Site Seeing

10.00 – 14.00

Interested individuals / Groups
Tour locations Include:

- Local Markets
- Museums
- Forts
- Shopping malls
- Bahrain International Circuit

3 Concurrent Workshops

10.00 – 13.00

Concurrent workshops covering the main tracks to be tackled at the conference. This will feature a large array of distinguished speakers from both public and private sectors from different regions in the world.

Return On Investment (ROI)

Dr. Jack Phillips

Founder and CEO of the ROI Institute - USA



Action Centred Leadership

Dr. Sunil Gupta

Chief Innovation Instigator & Chief Learning Officer
Ideas Management Consultants- India/Oman/UAE/USA



Leveraging of Social Media for Talent
Acquisition and Development

Mr. Ali Sabkar

President, Social Media Club -
Kingdom of Bahrain



Official Opening

19.00 – 22.00

Venue: Bahrain National Museum

- Recitation from the Holy Quran

- MC Opening speech

- President Message

Eng. Mohamed Mahmood Al Shaikh

BSTD President / IFTDO45

President - Kingdom of Bahrain



Introducing IFTDO Board Members

Keynote Speaker

**The future is today
Leadership & Change
Management**

H.E. Dr. Abdul Hussain bin Ali Mirza

Minister of Energy - Kingdom of Bahrain



-Awards recognition

-Group photo

-Dinner

PROGRAMME AT A GLANCE

Day Two

Tuesday, 22nd March 2016

Registration & Networking

07.30 – 09.00

Registration & Networking over Tea / Coffee

2 Speakers

09.00 – 10.30

Investing in people .. Knowing the Value

Dr. Jack Phillips
Founder and CEO of the ROI Institute - USA



Tackling the barriers to develop successful leaders (Overview and case study of Aramco)

Ms. Huda Al Ghoson
Executive Director - Human Resources at Saudi Aramco



Break – Opening of Exhibition

10.30 – 11.00

2 Speakers

11.00 – 12.30

The Challenge of Leadership in a Changing World

Mr. Peter Cheese
CEO, CIPD - UK



Organisation Transformation – Inspiring and Motivating your Team

Ms. Muna Al Hashmi
CEO, Batelco - Bahrain



Prayer Time & Lunch

12.30 – 14.00

2 Speakers

14.00 – 15.30

Women Leadership in Middle East

Prof. Beverly Dawn Metcalfe
Gender, HRM & Development.
The University of Manchester - UK



Innovative Leadership in the new Internet Era

Mr. Hani Nofal
INS Vice President, GBM - UAE



Break – Exhibition

15.30 – 15.45

Panel Discussion

15.45 – 17.00

Leadership Challenges in Developing HiPos

GALA DINNER

19.00 – 22.00

- Networking over Tea /Coffee
- Gala Dinner Ceremony
- Dinner

* Participants will be escorted by busses to the gala dinner location

PROGRAMME AT A GLANCE

Day Three

Wednesday, 23rd March 2016

Networking

07.30 – 09.00

Networking over Tea /Coffee

2 Speakers

09.00 – 10.30

Leadership and Dealing with Diversity

Mr. Christian Zandonella
*General Manager
The Ritz-Carlton, Bahrain*



Trustworthy Leadership

Dr. Najji Al Mahdi
Advisor - UAE



Break – Exhibition

10.30 – 11.00

2 Speakers

11.00 – 12.30

Leadership and Change Management

Mr. Tim Murray
CEO - ALBA



*Revolved Around Leadership
Coca Cola Case Studies*

Mr. Mohamed Akeel
*Managing Director - Coca Cola
Middle East*



Prayer Time & Lunch

12.30 – 14.00

Networking over Tea /Coffee

Exhibition

3 Speakers

14.00 – 15.30

*The Integrated Prophet Mohammad
Leadership Transcends Contemporary
Leadership Theories.*

Prof. Abdulbari Dura
*Member and Founder of the IFTDO
- USA*



*How to manage MultiGenerational
Workforce in the GCC*

Dr. Ramin Mohajer
*HR & Development Consultant
- CEO's Office Information
Technology Authority - Sultanate
of Oman*



Leading HRD Practice through Research

Mr. Ronald L. Jacobs
*Principal, RL Jacobs & Associates
- USA*



Closing Ceremony

15.30 – 16.00

EXHIBITION

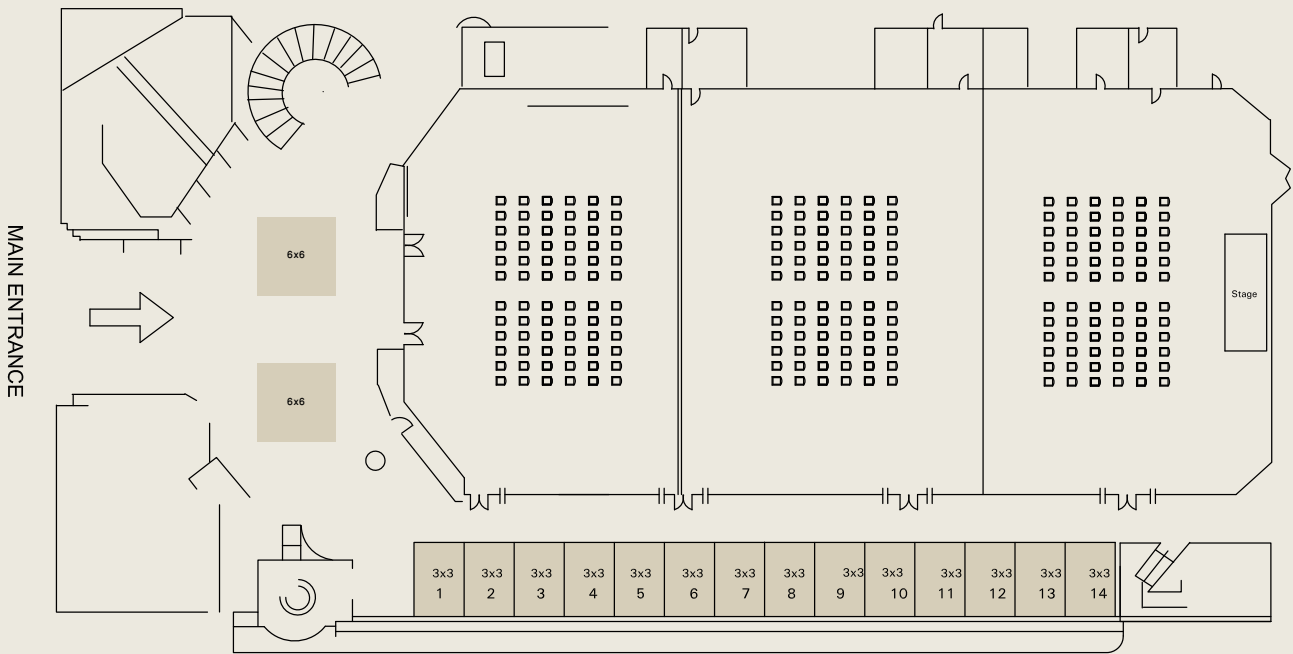

Venue:
 Bahrain Conference Center
 Crowne Plaza Hotel
 Diplomatic Area, Kingdom of Bahrain





SPEAKERS

The Majority of the speakers will be Chief Executives, Regional Directors, Chiefs of various types of operations, Specialists and Professionals representing Europe, USA, Asia, Middle East and Local Culture, to transfer and allocate their knowledge and experience in Human Capital Development and Leadership with the participants.

In addition to day one activities, there will be concurrent workshops covering the main tracks to be tackled at the conference. This will feature a large array of distinguished speakers from both public and private sectors from different regions of the world.

KEY SPEAKERS PROFILE

21st March 2016
Time: 19.00 – 22.00



Topic: *The Future is Today - Leadership & Change Management*

H.E Dr. Abdul-Hussain bin Ali Mirza
Minister of Energy - Kingdom of Bahrain

H.E. Dr Abdul-Hussain Bin Ali Mirza is the Minister of Energy and Chairman of The National Oil and Gas Authority. Prior to his post, he served as Minister of State for Cabinet Affairs and Minister of State. His Excellency is the chairman of The Oil & Gas Holding Company, Bapco Board and Tatweer Petroleum. His experience in the oil industry and The Bahrain Petroleum Company (Bapco) spans over 47 years entrusted with many executive positions such as General Manager Administration, General Manager Services, Corporate Secretary to the Board of Directors and Acting Chief Executive. For more than 25 years, Dr Mirza had been a member of Bapco's Executive Committee, playing a vital role in articulating Bapco's strategies.

22nd March 2016
Time: 09.00 – 09.30



Topic: *Investing in People...Knowing the Value*

Dr. Jack Phillips
Founder and CEO of the ROI Institute - USA

Dr. Jack J. Phillips is Chairman of the ROI Institute, the leading provider of services for measurement, evaluation, metrics, and analytics. Former Learning and Development Director, HR Executive, and Bank President, Phillips provides consulting services for over half of the Fortune 100 companies and conducts workshops for major conference providers worldwide. Phillips regularly consults with clients in manufacturing, service, and government organizations in over 60 countries in North and South America, Europe, Middle East, Africa, Australia, and Asia. He is the author of the first book on training evaluation in the USA and has authored or edited more than 75 books. Phillips is the developer of the ROI Methodology, the most used evaluation system in the world. His work has been featured in the Wall Street Journal, BusinessWeek, and Fortune magazine. He has been interviewed by several television programs, including CNN.

22nd March 2016
Time: 09.30 – 10.00



Topic: *Tackling the Barriers to Develop Successful Leaders*
(Overview and case study of Aramco)

Ms. Huda Al Ghoson
Executive Director, Human Resources at Saudi Aramco - KSA

Huda is the first woman to be named a permanent executive director in the company's history. Responsible for Saudi Aramco's overall HR strategy, her remit covers workforce planning, staffing, leadership and professional development, compensation and benefits, organization consulting, performance management, retirees' services and labor relations. Since joining Saudi Aramco in 1981, Huda has held a variety of positions within HR, and before her present appointment was General Manager of Training & Development.

22nd March 2016
Time: 11.00 – 11.30



Topic: *The Challenge of Leadership in a Changing World*

Mr. Peter Cheese
CEO, CIPD - UK

Peter is the chief executive of CIPD, the professional body for HR and people development. Prior to joining the CIPD in July 2012, he was Chairman of the Institute of Leadership and Management and a member of the Council of City&Guilds. Up until 2009 he had a long career at Accenture holding various leadership positions and culminating in a seven year spell as Global Managing Director leading the firm's human capital and organisation consulting practice. He writes and speaks widely on the development of HR, and the broader issues of leadership, culture, people and skills. Peter is also a member of the Board of BPP University, and the Advisory Board for the Open University Business School. He holds an honorary doctorate from Kingston University, is a Fellow of the CIPD and a Fellow of AHRI, the Australian HR Institute, a Companion of the Institute of Leadership and Management, and a Companion of the Chartered Management Institute.

KEY SPEAKERS PROFILE

22nd March 2016
Time: 11.30 – 12.00

Topic: *Organisation Transformation – Inspiring and Motivating your Team*



Ms. Muna Al Hashemi

CEO - Batelco - Kingdom of Bahrain

Muna Al Hashemi was appointed as Chief Executive for Batelco's Bahrain operations in August 2015, following seven months as A/CEO. Previously, Muna had been heading Batelco's Consumer Division since 2008 having joined the Company in 1994. With a Master's degree in Telecommunications and a BSc in Electronic Engineering, Muna began her career in the Engineering Department and gained valuable experience as she progressed through a number of divisions, including Customer Services, Accounts, Product Marketing, Product Development and Customer Marketing. The depth of knowledge of various functional units and processes that Muna gained in her diverse roles including the experience gained over seven years as General Manager of the busy Consumer Division and seven months as Acting CEO, provides her with the necessary skills for the challenging task of leading Batelco's Bahrain operations as CEO.

22nd March 2016
Time: 14.00 – 14.30

Topic: *Women Leadership in Middle East*



Prof. Beverly Dawn Metcalfe

Gender, HRM & Development. The University of Manchester - UK

Beverly Dawn Metcalfe is Professor of Gender and International HRD, and the Academic Director of the MSc HRD (International Development) at the Global Development Institute at the University of Manchester. Prof Metcalfe has published widely in the fields of National HRD, leadership and women's empowerment, and is the author of Leadership Development in the Middle East published in 2012. She has work and research experience in Australia, Bahrain, Malaysia, Oman, Russia, Singapore, Saudi Arabia, UAE, and the USA. She has held Visiting Professor positions at St Petersburg State University; Monash University, Griffith University; AUC and Helwan University in Egypt, and has recently been appointed as Visiting Professor at the American University in Beirut. Her current research examines women's leadership in the Middle East and their role in economic and social change. In her work Professor Metcalfe highlights the importance of Arab heritage and knowledge in supporting leadership and skills development.

22nd March 2016
Time: 14.30 – 15.00

Topic: *Innovative Leadership in the new Internet Era*



Mr. Hani Nofal

Vice President, Intelligent Network Solutions, GBM - UAE

Hani is in charge of leading the INS organization across the Gulf and Pakistan with responsibilities to focus on customer satisfaction, profitable growth and building a strong solutions and services portfolio. In his role, he is also in charge of the development of strategies for maintaining and growing relationships with strategic partners and alliances.

Prior to joining GBM, Hani was Cisco's Senior Regional Manager. During his tenure at Cisco, Hani supported the company's rapid growth and expansion in the UAE and Gulf and was responsible for several strategic successes in the region, achieving significant agreements and milestones.

KEY SPEAKERS PROFILE

23rd March 2016
Time: 09.00 – 09.30



Topic: Leadership and Dealing with Diversity

Mr. Christian Zandonella

GM - The Ritz-Carlton, Bahrain Hotel & Spa - Kingdom of Bahrain

Christian Zandonella has been appointed as General Manager of The Ritz-Carlton, Bahrain Hotel & Spa. Combining a passion for excellence and an understanding of today's global discerning travelers, he will continue to establish the hotel's prominent position within the local, regional and international market. Christian arrives in Bahrain from The Ritz-Carlton, Toronto which has received numerous awards both locally and internationally and is a sought after model in the Canadian service industry. In his leadership roles, Christian also contributed to many successes at award-winning Ritz-Carlton properties around the world including, Cancun, Grand Cayman, the Hotel Arts, Barcelona and Dorado Beach a Ritz-Carlton, Reserve.

23rd March 2016
Time: 09.30 – 10.00



Topic: Trustworthy Leadership

Dr. Naji Al Mahdi

Advisor - UAE

Dedicated Human Resources Development and Management professional with over 30 years experience in the field. Also a Fulbright Scholar in Small Business development in the United States. Held senior management roles within the education, training and employment sectors. Performance record includes providing strategic, academic and operational leadership to promote high level of performance and innovation in the development and delivery of quality vocational education in accordance to the needs of the business community and society at large. Has a wealth of experience in developing policies and strategies relating to the performance and organization at all levels of development and implementation.

23rd March 2016
Time: 11.00 – 11.30



Topic: Leadership and Change Management

Mr. Tim Murray

CEO, ALBA - Kingdom of Bahrain

Tim Murray has been Chief Executive Officer of Alba since October 2012. He has been with Alba since 2007 when he joined as General Manager of Finance. During his time at Alba he has held the roles of Chief Finance & Supply Officer, Chief Financial Officer, and Chief Marketing Officer. Tim played an instrumental role in Alba's IPO where the company listed on both the London and Bahrain Stock exchanges in November 2010. Before joining Alba, Mr Murray spent 10 years at ARC Automotive where in his last role he was Vice President and Chief Financial Officer. Tim holds an MBA from Vanderbilt University and a Bachelor of Science in Accounting from Susquehanna University.

23rd March 2016
Time: 11.30 – 12.00



Topic: Revolved Around Leadership Coca Cola Case Studies

Mr. Mohamed Akeel

Managing Director - Coca Cola - Kingdom of Bahrain

A deeply passionate, result oriented Leader with diverse operational experience of +25 years in roles of increasing responsibility and complexity, requiring provision of leadership to People and Thought Leadership to the India business. Possess 15 years of pre Coca-Cola experience, predominantly in leadership roles within the Fast Moving Consumer Durables industry across India. Previously part of the Senior Management Team of BIG's operations in India (Hindustan Coca-Cola Beverages Private Limited) leading national Commercial function. Currently managing bottling operations of Bahrain and Qatar.

KEY SPEAKERS PROFILE

23rd March 2016
Time: 14.00 – 14.30

Topic: *The Integrated Prophet Mohammad Leadership Transcends Contemporary Leadership Theories.*



Prof. Abdul Bari Ebrahim Dura

Member and Founder of the IFTDO - JORDAN / USA

The professor Abdul Bari Dura is one of the rare Arab personalities that has worked very hard with dedication to developing the administrative sector in the Arab world, noting that he had earned a PhD in Administration from the University of South California (USC) to become a certified professor.

Working in various foreign and Arab countries and took over several administrative leading positions in formal and private universities, like; University of Isra and University of the Middle East for Higher Education in Jordan. He is also a member of the International Federation of Training and Development Organisations, noting that he has published various unique books in the administrative field.

23rd March 2016
Time: 14.30 – 15.00

Topic: *How to manage MultiGenerational Workforce in the GCC.*



Dr. Ramin Mohajer

HR & Development Consultant - CEO`s Office
Information Technology Authority - Sultanate of Oman

Dr. Ramin Mohajer, Graduated in an Honors Bachelor "Microbiology with Biochemistry & Physiology" and Masters in "Food Science" both from the University of Reading (UK), PhD in Bus-Economics from the University of London, and an MBA from Victoria University (Melbourne, Australia).

Worked internationally for Glaxo Group Research as well as the Royal Berkshire

Hospital in the UK, Coles-Myer Group in Australia, and the Australian Federal Government in Canberra. Locally, for Muscat Municipality as well as the Sohar Development Office (Diwan of the Royal Court) as Training and Development Advisor, the Wave Muscat in the field of HR as well as Communications, and currently as the HR & Development Advisor to the CEO, at the Information Technology Authority ITA in the Sultanate of Oman.

23rd March 2016
Time: 15.00 – 15.30

Topic: *Leading HRD Practice through Research*



Dr. Ronald L. Jacobs

Principal, RL Jacobs & Associates - USA

Ronald L. Jacobs, Ph.D. is professor of human resource development, University of Illinois at Urbana-Champaign, and principal of RL Jacobs & Associates. Ron has written over 100 journal articles and book chapters, and has authored or edited six books that address a range of topics in human resource development. Ron is an emeritus professor at The Ohio State University.

In 1994, Ron received the instructional technology research award from the American Society for Training and Development. In 1995, the Academy of Human Resource Development honored Ron for his scholarly contributions to the human resource development field.

PRE-CONFERENCE CONCURRENT WORKSHOPS

Day One | Monday, 21st March 2016 | 10.00 – 13.00 hrs

* Seats will be allocated as per earlier registration

WORKSHOP 1

RETURN ON INVESTMENT (ROI)



Dr. Jack Phillips

Founder and CEO of the ROI Institute - USA

Dr. Jack J. Phillips is Chairman of the ROI Institute, the leading provider of services for measurement, evaluation, metrics, and analytics. Former Learning and Development Director, HR Executive, and Bank President, Phillips provides consulting services for over half of the Fortune 100 companies and conducts workshops for major conference providers worldwide. Phillips regularly consults with clients in manufacturing, service, and government organizations in over 60 countries in North and South America, Europe, Middle East, Africa, Australia, and Asia. He is the author of the first book on training evaluation in the USA and has authored or edited more than 75 books. Phillips is the developer of the ROI Methodology, the most used evaluation system in the world. His work has been featured in the Wall Street Journal, BusinessWeek, and Fortune magazine. He has been interviewed by several television programs, including CNN.

WORKSHOP 2

ACTION CENTRED LEADERSHIP



Dr. Sunil Gupta

Chief Innovation Instigator & Chief Learning Officer
Ideas Management Consultants- India/Oman/UAE/USA

Dr. Sunil Gupta have more that 36 years experience in Academic, Industry, Training & Consulting Experience in 40 countries, working with Cultural Diversity (81 nationalities). Last Line Assignment was as Corporate Manager, HRD, Colgate Palmolive Inc. He is currently the CHIEF INNOVATION INSTIGATOR & CHIEF LEARNING OFFICER, IDEAS MANAGEMENT CONSULTANTS- INDIA/OMAN/UAE/USA.

Dr. Sunil received Special recognition from Prime Minister's Office UAE and Bahrain, Several prestigious awards for academic excellence and other awards in Training & Development.

WORKSHOP 3

LEVERAGING OF SOCIAL MEDIA FOR TALENT ACQUISITION AND DEVELOPMENT



Mr. Ali Sabkar

President, Social Media Club
Kingdom of Bahrain

Mr. Ali SABKAR is the Founder & President of Social Media Club Bahrain who was the first to lead the social media activities & events in Bahrain.

Sabkar was appointed as Board of Director at Social Media Club USA in the capacity of Global New Chapter Management Director as first non USA citizen at the Global Board. Ali Sabkar was appointed by DM3 Institute UAE & DMi Group Ireland to be the first certified Bahraini instructor at the Professional Diploma in Digital Marketing. Sabkar is a co-author of a published book "WHY MARKETING Middle East" with 2 well known international internet marketing experts; it is The Revolutionary Strategy to Attract Ideal Customers.

EXHIBITOR FORM (A)



www.iftdo2016.com

21-23 March 2016
Bahrain Conference Centre
Crowne Plaza
Kingdom of Bahrain

POWERED BY



Rental of exhibition shell scheme, booths, 2.4m high anodized system post and beams with white color polkem infill panels

The Shell scheme (min. 9m² includes)

- White wall panels (height 2.4m)
- Carpet
- Fascia Board with company name in English
- Table with 2 chairs
- Two Fluorescent lights
- One 13 Amp single phase power point
- One Waste paper basket

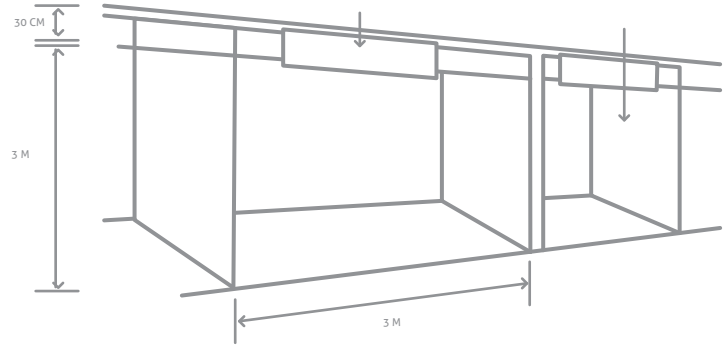

Booking Details

Name : _____
Position : _____
Company : _____
Address : _____
Postal Code: _____
City : _____ Country _____
Phone : _____ Fax: _____
E-mail : _____
Products to Exhibit: : _____

Participation Charges

Option A	BD 90
Minimum Space size 9 m²	Per m²
Space only (without exhibition stand)	

Option B	BD 110
Minimum Space size 9 m²	Per m²
Space with shell scheme package	

Space Requirement

- 9 Sqm 18 Sqm 27 Sqm
 Others (Please Specify)

Payment Method: Full payment in advance in favor of Origin Consulting Co. W.L.L

Bank: Bank of Bahrain & Kuwait

Swift code: BBKUBHBM

IBAN No. BH21 BBKU 00100 000 2785 70

Credit Card : American Express Visa Masters Card Cash

Card No.

Event Management



For Conference exhibition's registration please contact:
Ms. Anita / Mr. Ammar
Tel : +973 17 552 878 / Fax: +973 17 552 890
E-mail : registration@origin.com.bh
Web : www.origin.com.bh

Exhibition Management



Phone: +973 13 666 777 Fax: +973 13 666 888
PO Box 80522, Manama, Kingdom of Bahrain
E-mail : farooq@unicoopers.com
Web: www.unicoopers.com

CONFERENCE VENUE

CROWNE PLAZA HOTEL



DINING



ACCOMODATION



EVENT HALL



SWIMMING POOL

For Hotel booking, please contact :



Tel. +973 17531122
Website : <http://www.cp-bahrain.com>



Bahrain Society for Training & Development (BSTD)
Tel : +973 17 825 518 Fax : +973 17 825 517
Email : info@bstdbh.org



Ms. Anita Monteiro / Mr. Ammar Al Khabbaz
Telephone No. +973 17552878
Mobile No. +973 37 700 036 / +973 39 860 415

ARAD FORT



Arad Fort is one of Bahrain's most important fortified castles. The Fort was built in the style of Islamic forts at the end of the 15th and early 16th centuries. Due to its strategic location overlooking various sea passages of Muharraq Island, Arad Fort was used as a defensive fortress throughout history, from the time Bahrain was occupied by the Portuguese in the 16th century to the reign of Shaikh Salman Bin Ahmed Al-Khalifa in the 19th century.

Arad Fort was most recently restored in the 1980s, a process which took three years. In order to maintain the historical authenticity and value of Arad Fort, exclusively traditional materials were used, such as coral stone, lime and tree trunks. It is believed that the fort was used by the Omanis during their brief occupation of Bahrain in 1800, and it is located adjacent to the strategic waterways between Bahrain Island and Muharraq Island.

For more information, feel free to contact event management:

Ms. Anita Monteiro / Mr. Ammar Al Khabbaz

Telephone No. +973 17 552 878 / Mobile No. +973 37 700 036 / +973 39 860 415

HOTEL ACCOMODATION

5 STARS HOTELS

CROWNE PLAZA HOTEL

Single Standard Room (with breakfast)	BD 78 ++
Double Standard Room (with breakfast)	BD 88 ++

ART ROTANA AMWAJ

Single Standard Room	BD 75 ++
Double Standard Room	BD 85 ++

DOMAIN HOTEL

The Executive Room (with breakfast)	BD 68 ++ single room	BD 76 ++ Double room
The Junior Suite (with breakfast)	BD 83 ++ single room	BD 91 Double room

THE DIPLOMAT RADISSON BLU HOTEL

Single Standard Room (with breakfast)	BD 73 ++
Double Standard Room (with breakfast)	BD 81 ++

GOLDEN TULIP HOTEL

Standard Room	BD 45 single room	BD 50 Double room
De Luxe Room	BD 55 single room	BD 60 Double room

4 STARS HOTELS

NOVOTEL HOTEL

Superior Room	
Single (Bed & Breakfast)	BD 68++
Double (Bed & Breakfast)	BD 76++

*** All above rates are subject to change**

For more information about other hotels, Please contact:

Ms. Anita Monteiro / Mr. Ammar Al Khabbaz

Telephone No. +973 17552878 / Mobile No. +973 37 700 036 / +973 39 860 415

Email: anita@origin.com.bh

Registration FORM



POWERED BY



www.iftdo2016.com

21-23 March 2016
Bahrain Conference Centre
Crowne Plaza
Kingdom of Bahrain

Please complete the registration form in CAPITAL LETTERS and send it back by **fax (+973) 17-552 890** or contact **tel. (+973) 17-552 878** for further details.

Organization name	<input type="text"/>		
Contact person	<input type="text"/>		
Job Title	<input type="text"/>		
Mailing address	<input type="text"/>		
E-mail	<input type="text"/>		
Telephone	<input type="text"/>	Fax	<input type="text"/>
Mobile	<input type="text"/>		
Authorized Signature	<input type="text"/>	Date	<input type="text"/>

Payment Method:

Please make payments in favour of :

Account Name:

Origin Consulting Co. W.L.L

Bank: **BBK**

IBAN Number:

BH 21 BBKU 0010 0000 278 570

S/N	DELEGATE	JOB TITLE
1		
2		
3		
4		
5		
6		
7		
8		

* For additional registration, use a copy of this form.

Participation Fees

*Corporate rate available

- | | |
|---|-----------------------------------|
| <input type="checkbox"/> Non IFTDO Members | :\$ 1350 / BHD. 510 |
| <input type="checkbox"/> IFTDO Members | :\$ 1250 / BHD. 475 |
| <input type="checkbox"/> Accompanying Person | :\$ 550 / BHD. 208 |
| <input type="checkbox"/> Pre-conference workshop only | :\$ 160 / BHD. 61 |

Please confirm your attendance:

- | |
|---|
| <input type="checkbox"/> Attending one of the pre-conference workshops. |
| <input type="checkbox"/> Attending the Gala Dinner. |

The conference fee will include:

- Attending one of the pre-conference workshops.
- All conference sessions.
- The gala dinner.
- The exhibition.
- Full conference materials.
- Lunch, tea and coffee.
- A certificate.

Cancellation/Substitutions No cancellation will be permitted once a registration form is received. However, substitution is allowed.

EVENT ORGANISER



EVENT MANAGER



HOW TO REGISTER

- | | |
|--|--|
| | +973 17 552 878 |
| | +973 17 552 890 |
| | registration@origin.com.bh |



45TH IFTDO

WORLD CONFERENCE & EXHIBITION

LESSONS FROM LEADERS

www.iftdo2016.com

Event Organiser



Bahrain Society for
Training & Development (BSTD)
Tel : +973 17 825 518
Fax : +973 17 825 517
Email : info@bstdbh.org

Event Manager

ORIGIN
GROUP

+973 17 552 878
+973 17 552 890
+973 377 933 88
www.origin.com.bh
Registration@origin.com.bh